



Frequency and Time Measurements With the New -hp- High Speed Counter

Vol. 6 No. 12
Vol. 10 No. 3-4

ABOUT three years ago -hp- introduced the 10-megacycle frequency counter. This instrument was designed to simplify the problem of making precision measurements of frequency. In place of conventional measurement set-ups involving frequency standards, interpolation oscillators, mixers and oscilloscopes, the 10-megacycle counter was a single instrument that could by itself make precision frequency measurements automatically. In operation the counter was so simple that with it non-technical personnel could make measurements in a fraction of the time required for technical personnel to make the same measurements with an array of conventional equipment.

Although the 10-megacycle range of the counter includes the greater portion of ordinary frequency-measuring applications, the

advantages of the counter led to requirements to extend the measurement range to higher and higher frequencies. Consequently, -hp- recently introduced a frequency converter¹ which enables measurements to be made with the counter to 100 megacycles.

As a result of further requirements for the counter, it has now been provided with several companion instruments which permit frequency measurements to be made to 220 megacycles and which permit time interval measurements to be made over a range from 1 microsecond to 10⁷ seconds. In addition, the counter itself has been mechanically redesigned to simplify the use of these instruments.

FREQUENCY MEASUREMENTS

The new Model 524B counter is shown in

Figs. 1 and 2. By itself the instrument is capable of measuring frequencies as high as 10 megacycles and as low as 0.01 cps. To operate the instrument it is only necessary to connect to a panel connector the frequency to be measured. The value of the measured frequency is then automatically presented on the digital type display system shown in Fig. 3.

Electrical operating principles of the counter are indicated by the diagram of Fig. 4. The fre-

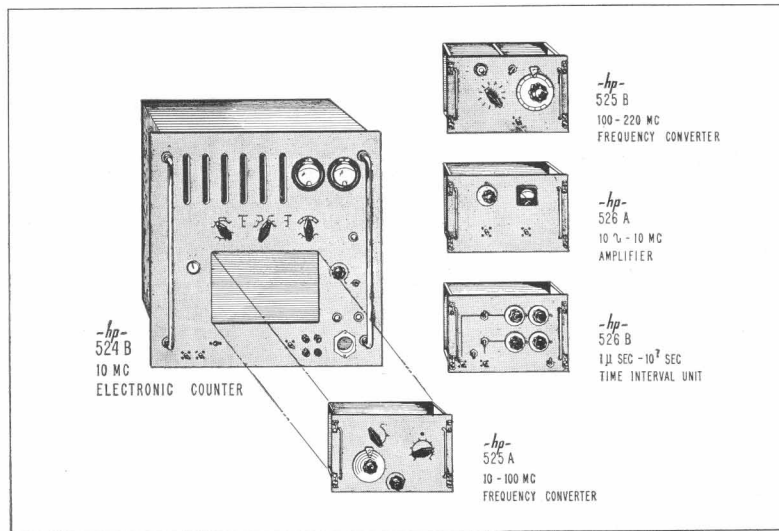

Fig. 1. New -hp- Model 524B Electronic Counter measures frequencies to 10 megacycles. Four accessory equipments permit frequency measurements to 220 megacycles or time interval measurements from 1 microsecond to 10⁷ seconds. Each accessory equipment is designed to plug into panel opening, is powered from counter power supply.

¹Dexter Hartke, "Measurements to 100 Megacycles with the -hp- Frequency Counter," Hewlett-Packard Journal, Vol. 4, No. 11-12, July-August, 1953. Copies available upon request.



Fig. 2. Model 524B Counter with frequency converter plug-in unit in place.

quency to be measured is applied to an electronic gate whose opening and closing is controlled by a precision time base generator. When the gate is open, the frequency under measurement is passed to a series of digital type counters which record each cycle of the applied frequency. When the gate closes, the counters' display system indicates the total count. After an interval determined by the operator, the gate again opens and another measurement is automatically made. The measuring process continues to repeat in this fashion so that drifts or changes in the measured frequency can be readily observed. If desired, the operator can set a panel control so that the measurement will be made only once rather than repetitively and so that the measured value will be displayed for as long as desired.

In order to make the counting arrangement direct-reading in frequency, *i.e.*, in events per unit time, the time base generator is designed to open the gate for an accurate interval of 1 second. The displayed count is thus given directly in cycles or events per second. For some purposes, however, it is convenient to have available gate times which are shorter or longer than 1 second. For example, when making rough tuning adjustments on oscillators, it is desirable that the measured frequency be displayed continuously rather than at 1-second intervals. This need is met by a panel control which permits the operator to select gate times as short as 0.001 second. Such gate times are sufficiently short that the visual persistence of the eye causes the reading to appear to be continuous. Five such gate times in decade-related steps are provided: 10, 1, 0.1, 0.01, and 0.001 seconds.

Each gate time changes by one the number of significant figures provided in the measured value. So that the displayed value will always be direct-reading and without uncertainty on the part of the operator, the display system includes an illuminated decimal point feature which automatically locates the decimal point for each gate time.

220 MC MEASUREMENTS

To extend the range of frequency measurements that can be made with

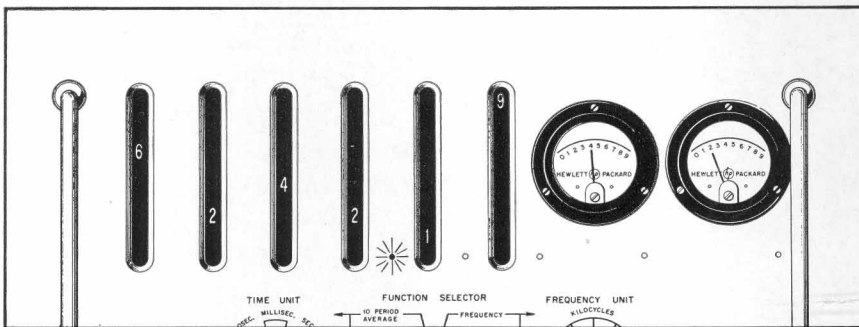

Fig. 3. Display system of Model 524B Counter. Reading shown when measuring a frequency of 6242.1942 kc. Illuminated decimal point is automatically positioned to prevent ambiguity in reading.

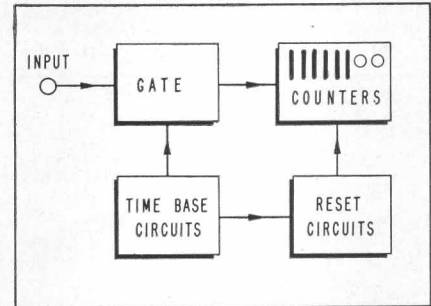

Fig. 4. Basic arrangement of counter circuits.

the counter, two frequency converters have been designed, the *-hp-* Models 525A and 525B. The 525A extends the measurable range from 10 to 100 megacycles, and the 525B from 100 to 220 megacycles.²

For convenience in using the instruments, the counter is constructed with an opening in the central portion of its panel. The converters are constructed to fit in this opening and to derive their power from the counter power supply. The combination of counter and either converter can then be operated as a single instrument.

Operation of the counter-converter combination is indicated in the block diagram of Fig. 7. The converters are similar to each other in operation, the main difference being in their frequency ranges. A standard frequency from the time base generator in the counter is multiplied so that it is available in the converter as multiples of 10 megacycles. These multiplied frequencies have the same accuracy as the counter time base (0.0002%). One of the multiplied frequencies is then mixed with the frequency to be measured to produce a difference frequency. The arrangement is such that the difference frequency is always less than 10 megacycles. This difference

²For use with the *-hp-* Model 524A Counter, these converters are available with built-in power supplies as the *-hp-* Models 512A and 512B respectively.

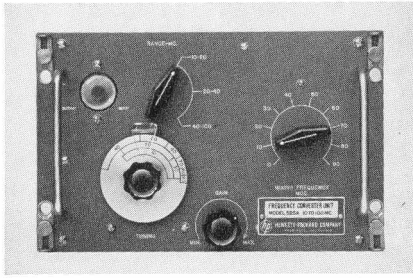

Fig. 5. Model 525A Frequency Converter plug-in unit measures frequencies up to 100 megacycles in combination with counter.

frequency is applied to the counter proper where it is measured. The value of the frequency being measured is thus the sum of the mixing frequency and the reading displayed by the counter. If a frequency of 195 megacycles were being measured, for example, a mixing frequency of 190 megacycles would be used in the converter. The difference frequency of 5 megacycles would be measured and indicated by the counter. Adding the difference frequency to the counter reading can easily be done mentally, because the mixing frequency is always a simple value such as 10, 20, 30 . . . 210 megacycles.

If the approximate value of the frequency to be measured is known, the converter switch that selects the mixing frequency can usually be set directly to the proper mixing frequency. But if the frequency to be measured is completely unknown, it is necessary to determine which mixing frequency should be used. This is easily done with the converter by means of a built-in preselector.

The preselector operates in combination with a tuning eye and calibrated dial which indicate the approximate value of the frequency being measured. Rather than being calibrated directly in terms of the unknown frequency, however, the preselector dial is calibrated so that it indicates the proper mixing frequency that should be used for the

measurement. When the mixing frequency selector switch is set to the indicated frequency, the difference frequency appears on the counter display system.

Measuring frequencies as high as 220 megacycles thus reduces to three simple steps: tuning the preselector, setting the mixing frequency selector switch to the proper position, and adding the mixing frequency to the reading displayed by the counter.

With either converter in place in the counter, measurements can be made in the 10 cps-10 mc range as well as in the range of the converter. In the case of the 100 mc converter, the frequency measurement sensitivity of the counter over the 10 cps-10 mc range is increased from 1 volt rms to 0.1 volt rms.

MEASUREMENT APPLICATIONS

The precision and exceptional speed with which the counter makes frequency measurements are such that it lends itself to many measurement applications which were at least inconvenient with conventional methods. Fig. 8, for example, shows frequency stability measurements made with the counter and converter on a signal generator operating at 200 megacycles. Two types of measurements were made. The first was an investigation of the effect of a varying line voltage on the output frequency of the generator. Line voltage was varied from 105 to 125 volts several times. The accompanying frequency changes are shown on an expanded scale in Fig. 8 (a). In Fig. 8 (b) is shown the warm-

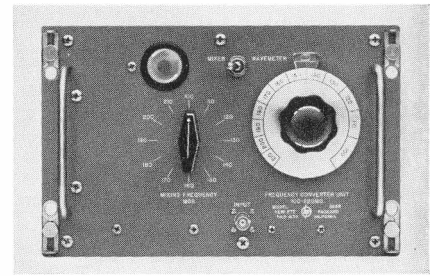

Fig. 6. Model 525B Frequency Converter plug-in unit measures frequencies up to 220 megacycles in combination with counter.

up characteristic of the generator as measured with the counter and converter. It is interesting to note that these measurements can be made with the counter by personnel completely untrained in electrical work after a few minutes' instruction.

Another investigation facilitated by the simplicity and speed of the counter is indicated in Fig. 9. This curve shows the effect of on-off cycling of a crystal oven heater on the frequency of a crystal-controlled oscillator. The object of the measurements was to gain information about the performance of a quality crystal oven. In order to magnify the effect of heater cycling, a crystal having a high temperature coefficient was used in the oven. Even so, the thermal isolation of the oven was such that the frequency excursions amounted to only 15 cps at 8 megacycles.

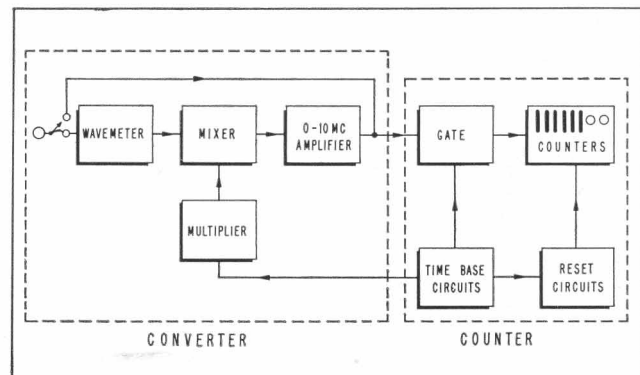

Fig. 7. Block diagram of combined circuit arrangement of frequency converter and counter.

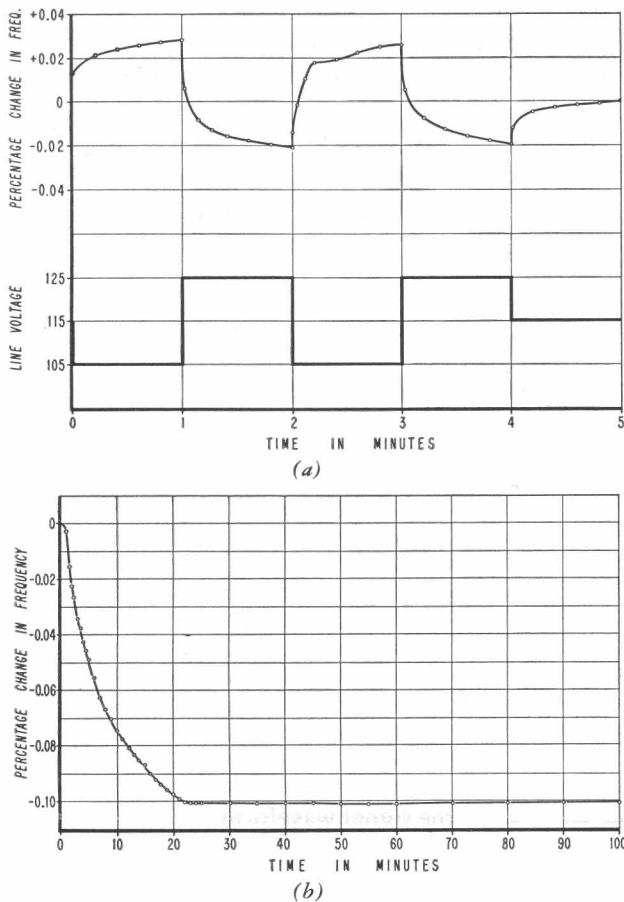

Fig. 8. Example of detailed frequency measurement made with counter and converter. In (a) the line voltage effect on a 200 mc oscillator is investigated. (b) shows measurement made of warm-up characteristic of same oscillator.

Although not apparent at first glance, it is interesting to note that the measurements reveal that the frequency changes are out-of-phase with the cycling of the oven heater. This occurred because of the high thermal isolation of the particular oven used.

A frequency counter also has many applications in industrial work. In high-speed tachometry applications, counters can be used with suitable tachometer generators or reflected-light type tachometer heads to make rpm or rps measurements of the fastest rotating devices.

ACCURACY OF FREQUENCY MEASUREMENTS

Frequency measurements made by the counter and converter are accurate within 0.0002% per week ± 1

count. The factor of 0.0002% per week is the tolerance in the operation of the time base generator. Over short time intervals this tolerance is increased to 0.0001%. Provision is made in the counter for use of an external frequency standard if a standard of higher accuracy than the internal standard is available. For all but the most demanding measurements, however, the accuracy of the internal system is adequate.

The time base generator in the counter derives its accuracy from a crystal-controlled oscillator. In order to insure that the stability of the crystal is suitable for the purpose, the crystal is mounted in its oven and placed in a special aging circuit. The frequency of the crystal is then measured daily for as much as 60 days' time so that its long-time stability characteristic can be accurately determined.

The ± 1 count tolerance in the operation of the counter is an inherent tolerance which occurs because of the possible random phasing of the measured frequency with respect to the arbitrary gate time. When measuring a frequency of 49.1 cps with a 1-second gate, for example, it would be possible for either 49 or 50 voltage peaks to pass through the gate, depending on the relative phase of the gate and signal voltage. The

counter would thus register 49 or 50 counts as the case may be.

On a percentage basis the importance of the ± 1 count tolerance depends on the total number of counts registered during a measurement. If 100 megacycles were being measured, the ambiguous count is insignificant because it amounts to but 1 part in 10^8 whereas the tolerance of the time base generator is 1 or 2 parts in 10^6 . But if a measurement is made such that only 100 counts are obtained, the possible error of 1 count amounts to 1 part in 10^2 or 1%.

As a result of this consideration, it is desirable to measure low frequencies indirectly, *i.e.*, by measuring their period ($1/f$). This technique is described later.

Maximum accuracy of the equipment for frequency measurements is summarized in Fig. 10.

SELF-CHECK FEATURE

In order that the operator can verify the proper operation of the counter, it has been designed so that it will self-check itself. A panel control connects the circuits so that a standard frequency of either 100 kc or 10 megacycles is applied to the gate and counters. Since the operator knows the values of these standard frequencies, he knows what the readings displayed should be and can thus check the equipment operation. The self-check feature can be used with any of the five gate times provided by the counter.

10-MEGACYCLE AMPLIFIER

The sensitivity of the 524B counter when making frequency measurements by itself in the range from 10 cps to 10 megacycles is such that the counter will operate from a signal voltage of 1 volt rms. If the 525A converter is used, the sensitivity in the 10 cps-10 mc range is increased to 0.1 volt rms.

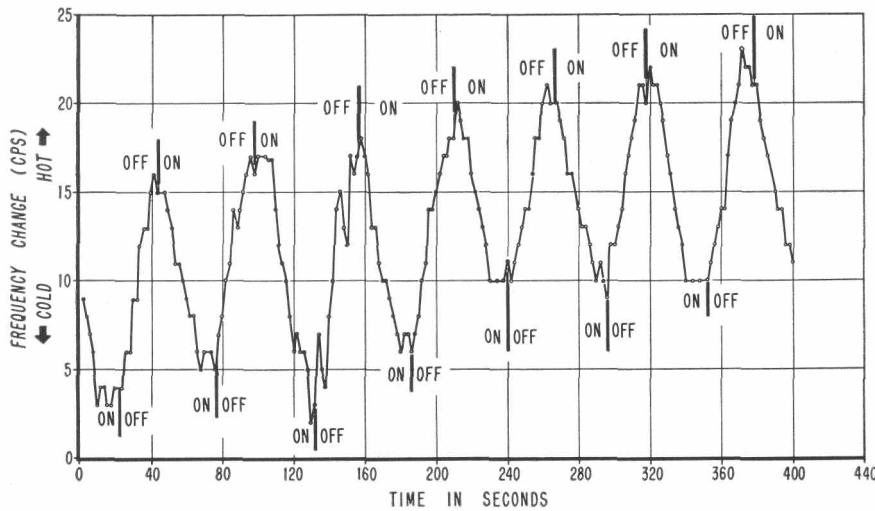

Fig. 9. Measurements made in course of development of a crystal oven. To expand data a high positive temperature coefficient 8 mc crystal was used. See accompanying text for discussion.

For applications where the converters are not used or where higher sensitivity is desired for measurements below 10 megacycles, a wide-band pre-amplifier has been designed. This amplifier, the *-hp-* Model 526A increases the sensitivity of the 524B counter to 10 millivolts rms. Like the other accessory equipments the amplifier is designed to fit in the panel aperture in the counter.

The amplifier is provided with a special output terminal which enables the signal being counted to be monitored by an oscilloscope. At this terminal the amplifier delivers approximately 10 times the signal input voltage from a source impedance of 93 ohms. A meter on the panel of the amplifier monitors the voltage level applied to the counter proper in order to give the operator a positive indication of the signal level.

Also provided with the amplifier is a probe which can be used where it is desirable to have an extra high input impedance for the amplifier. Use of the probe increases the input impedance of the amplifier from 1 megohm to 10 megohms shunted by approximately 15 micromicrofarads. Sensitivity of the equipment when using the probe is 0.1 volt rms.

TIME MEASUREMENTS

One of the special features of the new 524B counter is its ability to make direct-reading measurements of time intervals. Time measurements are made in combination with the new *-hp-* Model 526B Time Interval Unit shown in Fig. 12. This unit is constructed to be the same physical size as the other accessory equipments so that it will fit in the 524B panel opening.

Time measurements can be made of intervals as short as 1 microsecond or as long as 10^7 seconds. This wide

range enables the equipment to be used for nearly any type of time measurement including such measurements as the width or spacing of pulses, ballistics timing, timing of linear mechanical motion, measuring the phase delay in low frequency systems, etc.

To facilitate interval measurements, the 526B includes a special threshold feature which permits the measurement to be started and stopped only by signals of predetermined amplitude, polarity and slope. Separate start and stop channels are provided and each channel is separately adjustable so that a high degree of flexibility is obtained.

The threshold controls permit time interval measurements to be started or stopped at any voltage point from -192 to $+192$ volts on either positive or negative slopes of the signal waveform.

To illustrate how the threshold feature operates, assume that it is desired to make a measurement of the duration of the waveform shown in Fig. 13. By adjusting the controls on the start channel to trigger from a positive slope, positive voltage of suitable amplitude, the measurement will begin at the first voltage

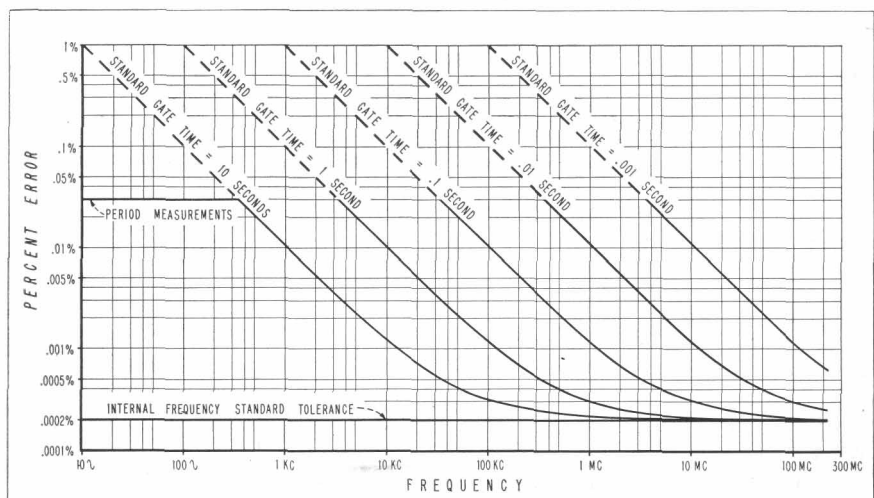

Fig. 10. Accuracy curve of Model 524B and converters, for frequency measurements from 10 cps to 10 mc.

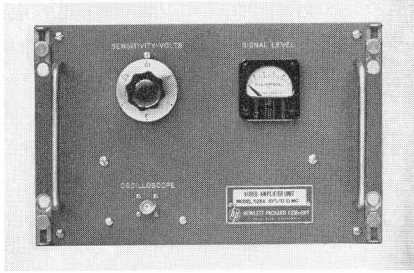

Fig. 11. Model 526A amplifier increases sensitivity of counter to 10 millivolts in 10 cps-10 mc range.

rise in the diagram. By suitably setting the controls on the stop channel, the measurement can be made to end so as to provide measurements of "A", "B", or "C", as desired.

The manner in which the Time Interval Unit operates with the counter is indicated in Fig. 14. The unit includes two trigger circuits with biasing networks which predetermine the driving voltage at which the trigger circuits fire. When the proper start voltage occurs, the start trigger circuit delivers within 0.1 microsecond a pulse that opens the gate in the counter. The counter then counts one of the standard frequencies from its time base generator until the proper stop signal occurs, at which the stop trigger circuit closes the gate.

In time interval measurements, the value displayed by the counters is direct-reading in units of time. This occurs because the standard frequencies counted during the

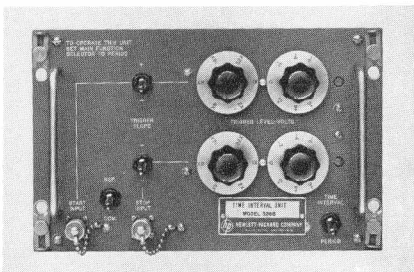

Fig. 12. Model 526B Time Interval Unit. Threshold controls give added flexibility to time interval measurements.

measurement have been selected so that their periods have a decade relation to "1." For example, the standard frequencies available for measuring time intervals are 10 cps, 1 kc, 100 kc, and 10 megacycles. Counting these frequencies presents the measurement in time units of 0.1 second, 0.001 second, 10 microseconds, and 0.1 microsecond, respectively. The automatically-placed decimal point precludes any ambiguity in the time units in which the measurement is presented.

A feature of the equipment that lends itself to specialized measurements is that external frequencies can be counted in place of the internal frequencies. By proper choice of the external frequency, the measured value can thus be obtained directly in units of yards, miles, or other arbitrary units.

ACCURACY OF TIME MEASUREMENTS

Time interval measurements are accurate within 0.0002% ± 1 period of the counted frequency, provided the rise times of the start and stop signals are negligible compared to the interval being measured. If the rise (or decay) of the start and stop signals is not negligible, the error introduced can be calculated from the fact that, voltage-wise, the trigger circuits operate accurately within approximately 1 volt. If start and stop signals each having a slope of 2 volts per microsecond are being used, the 1 volt trigger circuit uncertainty could thus introduce an error of approximately 1 microsecond in the measurement.

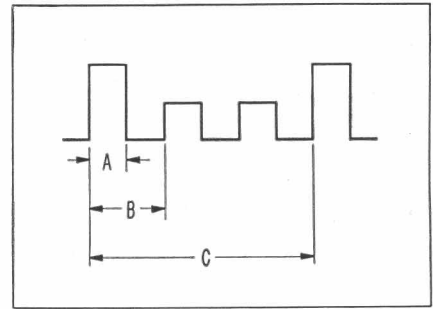

Fig. 13. Waveform illustrating some of time measurements that can be made with Time Interval Unit.

PERIOD MEASUREMENTS

The 524B counter is arranged so that it can measure the period of a frequency as well as measuring the frequency directly. Period measurements are often of value when measuring low frequencies below 300 cps, because better accuracy can be obtained than with a direct measurement of frequency. On direct frequency measurements, however, the counter can be used to measure frequencies as low as 10 cps.

To make period measurements, a panel switch on the counter connects the circuits in a manner similar to their arrangement for measuring time intervals. A standard frequency from the time base generator is applied to the counter circuits and the signal to be measured opens and closes the gate. As in time interval measurements, the frequencies available for counting are 10 cps, 1 kc, 100 kc, and 10 megacycles. Since the

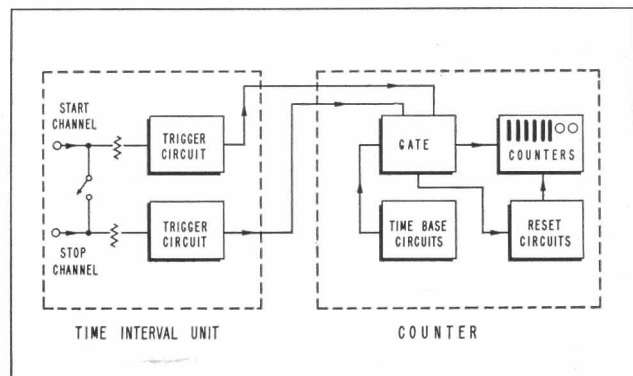

Fig. 14. Circuit arrangement of counter when used with Time Interval Unit.

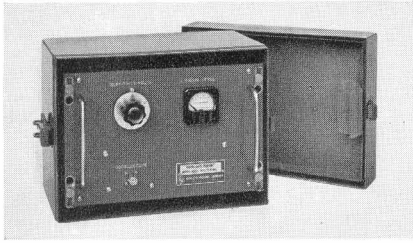

Fig. 15. Carrying case provided for additional plug-in units.

display system has a maximum capacity of 10^8 counts, periods as long as 10^7 seconds can theoretically be measured using the 10 cps standard frequency.

Period measurements are made without use of any circuits of the plug-in units and periods can be measured with any of the plug-in units in place. Although period and time interval measurements are similar, the design emphasis in the two cases is different. For time interval measurements, the special trigger circuits have been designed to achieve a speed of triggering of approximately 0.1 microsecond. For period measurements this speed of triggering is not required and a

simpler triggering circuit has therefore been used. The period trigger circuits operate within 0.3% time-wise for a 1-volt sine-wave signal voltage. The maximum error on period measurements is 0.03%, which is obtained when measuring the average of 10 consecutive periods. Ten period average measurements are made possible by an internal decade divider circuit and reduce the time effect of any triggering uncertainty by tenfold. The 0.03% error can be further reduced by using signal voltages higher than the 1-volt minimum permitted by the equipment.

TOTALIZING

The 524B counter is provided with a panel switch which can be used to open and close the gate manually. Manual gate operation is desirable in some applications where it is desired to measure the total number of electrical events that have occurred during time intervals longer than 10 seconds (the longest gate time provided by the counter).

For totalizing applications the

counter has a double pulse resolution of 0.1 microsecond, a triple pulse resolution of 0.2 microsecond, and counts signal voltages as low as 1.4 volt peak.

GUIDE TO PLUG-IN UNITS

The following table summarizes the various measurements that can be made with the 524B counter and the accessory equipments which are available. Specifically, the table shows which measurements can be made with any one plug-in equipment in place.

MISCELLANEOUS

The Model 524B counter is available either for rack-mounting or for table use (cabinet mount). A built-in forced air system is provided for cooling purposes. The blower is equipped with an air filter to minimize dust problems. The filter is a renewable type which has an indefinitely-long life since it can be cleaned with ordinary detergent and water.

The counter is arranged so that the heater for the crystal oven is always energized as long as the equip-

GUIDE TO OPERATION WITH PANEL PLUG-IN UNITS

TYPE OF MEAS'T	PANEL COVER	MODEL 525A	MODEL 525B	MODEL 526A	MODEL 526B
BELOW 10 MC	Yes Sens'y: 1 volt rms	Yes Sens'y: 0.1 volt rms	Yes Sens'y: 1 volt rms	Yes Sens'y: 0.01 volt rms	Yes Sens'y: 1 volt rms
10 MC -100 MC	No	Yes Sens'y: 0.01 volt rms	No	No	No
100 MC -220 MC	No	No	Yes Sens'y: 0.1 volt rms	No	No
TIME INTERVAL	No	No	No	No	Yes Sens'y: 1 volt peak
PERIOD AND 10 PERIOD AVERAGE	Yes Sens'y: 1 volt rms	Yes Sens'y: 1 volt rms	Yes Sens'y: 1 volt rms	Yes Sens'y: 1 volt rms	Yes Sens'y: 1 volt rms
TOTALIZING (MANUAL GATE)	Yes Sens'y: 1 volt rms	Yes Sens'y: 1 volt rms	Yes Sens'y: 1 volt rms	Yes Sens'y: 1 volt rms	Yes Sens'y: 1 volt rms

ment is connected to a power source. For this reason the equipment should be operated from a source as free as possible from interruption.

GENERAL

When the 524B counter is obtained without accessory plug-in equipments, it is supplied with a panel blank which covers the panel opening. The arrangement is such

that at a future time any of the plug-in equipments can be procured to operate with the basic counter.

If the counter is obtained with one accessory equipment, the panel blank is not supplied. If two or more accessory equipments are obtained, a convenient aluminum carrying case is supplied for all but one of the equipments.

SUPERSEDES MODEL 524A

The new Model 524B counter supersedes the *-hp-* Model 524A counter which has been discontinued. The 512A 100 mc converter and the 512B 220 mc converter will continue to be available for users of the 524A.

-Alan S. Bagley, Dexter Hartke, and Wm. D. Myers

SPECIFICATIONS

**-hp-
MODEL 524B
ELECTRONIC COUNTER**

Basic Unit (for Frequency Measurements from 0 cps to 10 mc)

FREQUENCY MEASUREMENT (without plug-in units)

RANGE: 10 cps to 10 mc.
GATE TIME: 0.001, 0.01, 0.1, 1, 10 seconds or manual control.
ACCURACY: ± 1 count \pm stability (see below).
READS IN: Kilocycles; decimal point automatically positioned.

PERIOD MEASUREMENT (without plug-in units)

RANGE: 0 cps to 10 kc.
GATE TIME: 1 or 10 cycles of unknown.
ACCURACY: $\pm 0.3\%$ (one period measurement) $\pm 0.03\%$ (ten period average).

STANDARD FREQUENCY COUNTED: 10 cps; 1 or 100 kc; 10 mc; or externally applied frequency.

READS IN: Seconds, milliseconds or microseconds; decimal point automatically positioned.

GENERAL

REGISTRATION: 8 places (99,999,999 maximum counts). First 6 places on neon lamp decades, last 2 on meters.

STABILITY: 1/1,000,000 short-term; 2/1,000,000 per week. May be standardized against WWV or used with external 100 kc primary standard for highest accuracy.

DISPLAY TIME: Variable 0.1 to 10 seconds in steps of gate time selected. Display can also be held indefinitely.

OUTPUT FREQUENCIES: Secondary standard frequencies available at front panel: 10 cps, 1 kc rectangular; 100 kc positive pulse; 10 mc sine wave. (Stability as above.)

SELF-CHECK: Panel control provides automatic count of internal standard 100 kc and 10 mc frequencies to insure accuracy of gate and proper operation of counters.

INPUT VOLTAGE: 1 v rms minimum.

INPUT IMPEDANCE: Approx. 1 megohm shunted by 40 mmf.

INPUT CONNECTOR: Type BNC jack.

POWER SUPPLY: 115/230v $\pm 10\%$, 50-1,000 cps, approx. 500 watts.

SIZE: Cabinet mount: 20 $\frac{3}{4}$ " w, 21" h, 19" d. Rack mount: 19" w, 19 $\frac{1}{4}$ " h, 17" d (behind panel).

WEIGHT: Cabinet mount: 132 lbs.; shipping wt. approx. 200 lbs. Rack mount: 112 lbs.; shipping wt. approx. 175 lbs.

ACCESSORIES FURNISHED: *-hp-* AC-16D cable assembly consisting of 42" of RG-58/U cable one end terminated with UG-88/U BNC connector, opposite end unterminated; *-hp-* 61B-16H power cable.

PRICE: *-hp-* 524B (cabinet mount): \$1,915.00 f.o.b. Palo Alto, Calif.
-hp- 524BR (rack mount): \$1,850.00 f.o.b. Palo Alto, Calif.

**-hp-
MODEL 525A
FREQUENCY CONVERTER**

(For frequency measurements from 10 cps to 100 mc)

(As plugged into *-hp-* 524B Electronic Counter)

RANGE: As amplifier for counter, 10 cps to 10 mc. As converter for counter, 10 mc to 100 mc.

ACCURACY: ± 1 cps \pm stability (See General).

REGISTRATION: 8 places; first place indicated on converter selector switch labeled 0, 10, 20 . . . 90; next 7 indicated by counter.

INPUT VOLTAGE: 0.1 v rms minimum, 10 cps to 10 mc; 10 mv rms minimum, 10 mc to 100 mc.

INPUT IMPEDANCE: Approx. 1 megohm shunted by 40 mmf, 10 cps to 10 mc; approx. 50 ohms, 10 mc to 100 mc.

LEVEL CONTROL: Tuning eye aids frequency selection, indicates correct voltage level.

SIZE: Supplied in aluminum storage case with carrying handle; case 12" wide, 9" high, 8" deep.

WEIGHT: 10 lbs., net, 19 lbs. packed.

PRICE: \$225.00 f.o.b. Palo Alto, California.

**-hp-
MODEL 525B
FREQUENCY CONVERTER**

(For frequency measurements from 100 mc to 220 mc)

(As plugged into *-hp-* 524B Electronic Counter)

RANGE: 100 mc to 220 mc.

ACCURACY: ± 1 cps \pm stability (see General).

REGISTRATION: 9 places; first two places indicated on converter selector switch labeled 100, 110, 120 . . . 210, next seven as indicated under General.

INPUT VOLTAGE: 0.1 rms minimum.

INPUT IMPEDANCE: Approximately 50 ohms.

SIZE & WEIGHT: Same as 525A above.

PRICE: \$225.00 f.o.b. Palo Alto, California.

**-hp-
MODEL 526A
VIDEO AMPLIFIER**

(For frequency measurements from 10 cps to 10 mc)

(As plugged into *-hp-* 524B Electronic Counter)

RANGE: 10 cps to 10 mc.

ACCURACY: Same as basic 524B Counter.

INPUT VOLTAGE: 10 mv rms minimum.

LEVEL CONTROL: Meter indicates correct input signal level.

OUTPUT TERMINAL: BNC connector provides 10 times input voltage from 93-ohm source. Allows oscilloscope monitoring of input signal without loading circuit.

READS IN: Same as basic 524B Counter.

ACCESSORIES FURNISHED: Supplied with *-hp-* 526A-16A probe assembly which increases input impedance to 10 megohms shunted by 15 mmf; maximum sensitivity using probe is 0.1 v rms.

SIZE: Supplied in aluminum storage case, with carrying handle, case 12" wide, 9" high, 8" deep.

WEIGHT: 10 lbs. net, 19 lbs. packed.

PRICE: \$125.00 f.o.b. Palo Alto, California.

**-hp-
MODEL 526B
TIME INTERVAL UNIT**

(For time interval measurement)

(As plugged into *-hp-* 524B Electronic Counter)

RANGE: 1 microsecond to 10⁷ seconds.

ACCURACY: ± 1 period of standard frequency counted \pm stability. (see General.)

REGISTRATION: Same as indicated under General.

INPUT VOLTAGE: 1 v peak minimum; direct-coupled input.

INPUT IMPEDANCE: Approx. 1 megohm shunted by 40 mmf.

START AND STOP: Independent or common channels.

TRIGGER SLOPE: Positive or negative on start and/or stop channels.

TRIGGER AMPLITUDE: Both channels continuously adjustable from -192 to +192v.

STANDARD FREQUENCY COUNTED: 10 cps, 1 or 100 kc; 10 mc or externally applied frequency.

READS IN: Seconds, milliseconds, or microseconds with automatic decimal point.

ACCESSORIES FURNISHED: *-hp-* AC-16D cable assembly consisting of 42" of RG-58/U cable terminated on one end with UG-88/U BNC connector, opposite end unterminated.

SIZE & WEIGHT: Same as 526A above.

PRICE: \$150.00 f.o.b. Palo Alto, California.

Data subject to change without notice